

- A. Wing window bars (mandatory)
- B. Wheel base (108" minimum)
- C. Mandatory safety plating ($\frac{1}{8}$ " steel minimum)
- D. Stock frame this point forward
- E. Rear tail section ($2" \times 3" \times .095$ wall steel tubing)
- F. Fuel cell can (material 20 gauge steel)
- G. Foot area protection bar (mandatory)
- H. All dark shaded bars may be $.065 \times 1\frac{1}{2}$ " minimum
- I. All cages must have these support bars
- J. Braced .065 fuel cell guard required
- K. $\frac{1}{8}$ " steel or $\frac{3}{16}$ " aluminum front and rear inspection plates required

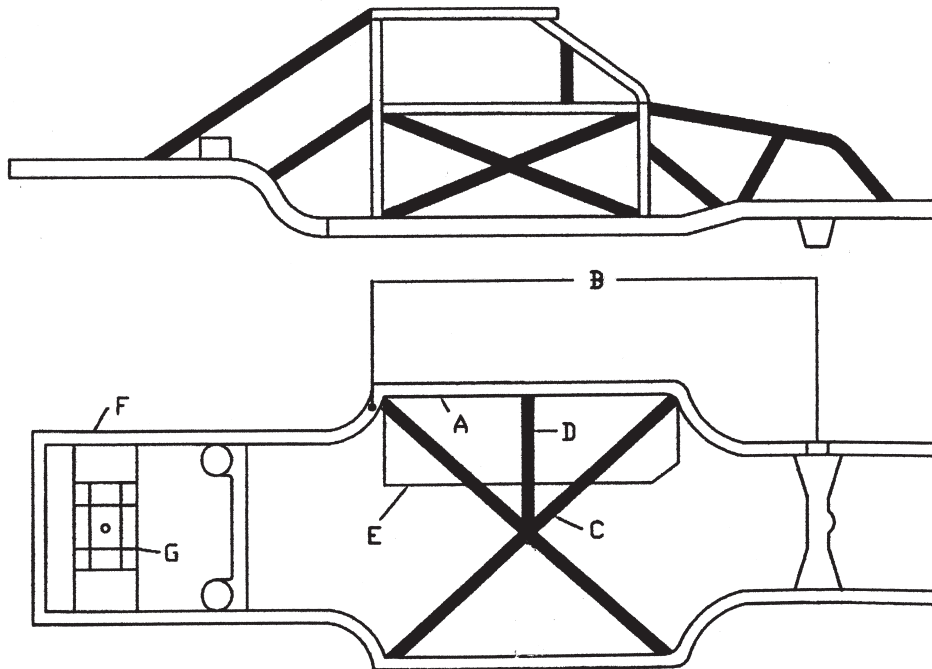

- A. Frame plating material ($4" \times \frac{1}{8}$ ") flat strap steel
 - B. Roll cage main hoop set back $82\frac{1}{2}$ ", measure from center of lower ball joint to back of main hoop tubing
 - C. Frames must be cross-braced or X-ed through center
 - D. Driver compartment safety bar (same material as X)
 - E. Floor plate $\frac{1}{8}$ " steel plate minimum 20" width at seat
 - F. Tail section replacement same dimensions as stock frame
 - G. Fuel cell safety straps (minimum 4) $1" \times 1\frac{1}{8}$ " strap steel
- NOTE: X-brace must tie into original frame, not frame plating.**

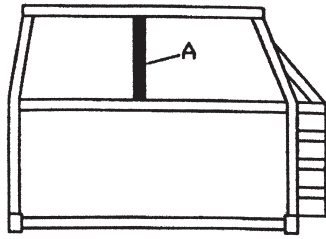

Cage viewed from front

- A. Minimum $1\frac{1}{2}'' \times .095$ dash bar to halo required

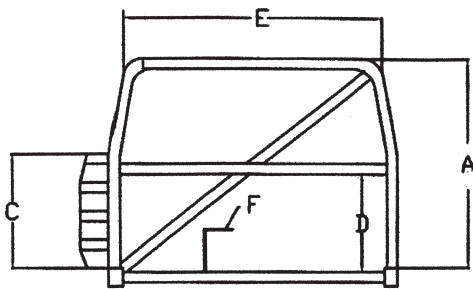

- A. Main hoop (vertical to frame) 39" high
- B. Door bars should be flush to door panel
- C. Door bar height minimum 20" from top of frame
- D. Cross bar recommended height 20"
- E. Roof/hoop to fit roof side to side 39" minimum
- F. $\frac{1}{8}''$ steel or $\frac{3}{16}''$ aluminum drive shaft protection required

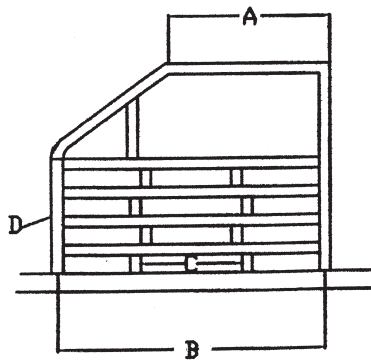

- A. 32" minimum length
- B. Door bar length 44"
- C. 2 door bar uprights between each door bar
- D. 4 door bars evenly spaced on driver side

NOTE: All driver side door bar material is a minimum $1\frac{3}{4}'' \times .095$.